

Resistore autoregolante 50Watt – 150Vc.c. completo di piastrine di ancoraggio

Kit per protezione antigelo di casse manovra tipo P80-L90

Self-regulating resistor 50Watt – 150Vc.c. with anchor plates
Frost protection of maneuver boxes type P80-L90

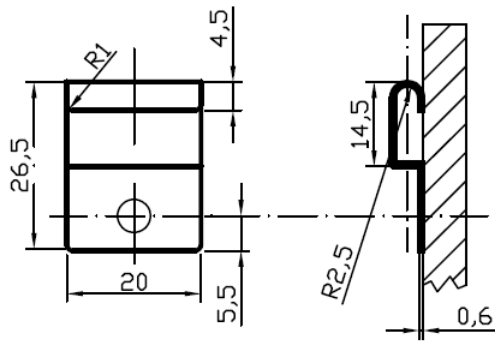

Bordi esenti da bave
 Edges free of burrs

- N. 3 piastrine di fissaggio resistore autoregolante mat. X8Cr 17 UNI 6900
 N. 3 fixing plates resistor self regulating. Mat. X8Cr 17 UNI 6900
- N. 3 rondelle UNI EN ISO 7089-2001 - 5,3x10 - A2L
 N. 3 washers UNI EN ISO 7089-2001 - 5,3x10 - A2L

